

HD30V5 Mini-Excavator



ACCESS KATO's V5 line features wide-opening access panels, large compartments for working around the engine, hydraulics, etc.



STABILITY V5 excavators are built on some of the industry's strongest and most stable track frames, maximizing job-site safety and minimizing equipment repairs.



CONTROL KATO's V5 line features highly responsive pilot controls and easy to read instrument panels, all within the most comfortable cabs on the market.



POWER The 30V5 is powered by a 23hp YANMAR engine, delivering more than 6,500 lbs of breakout force at the bucket.

KATO

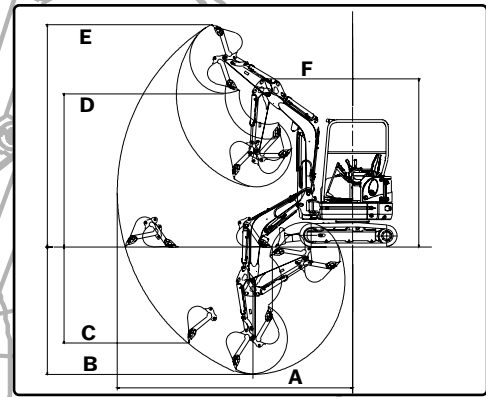
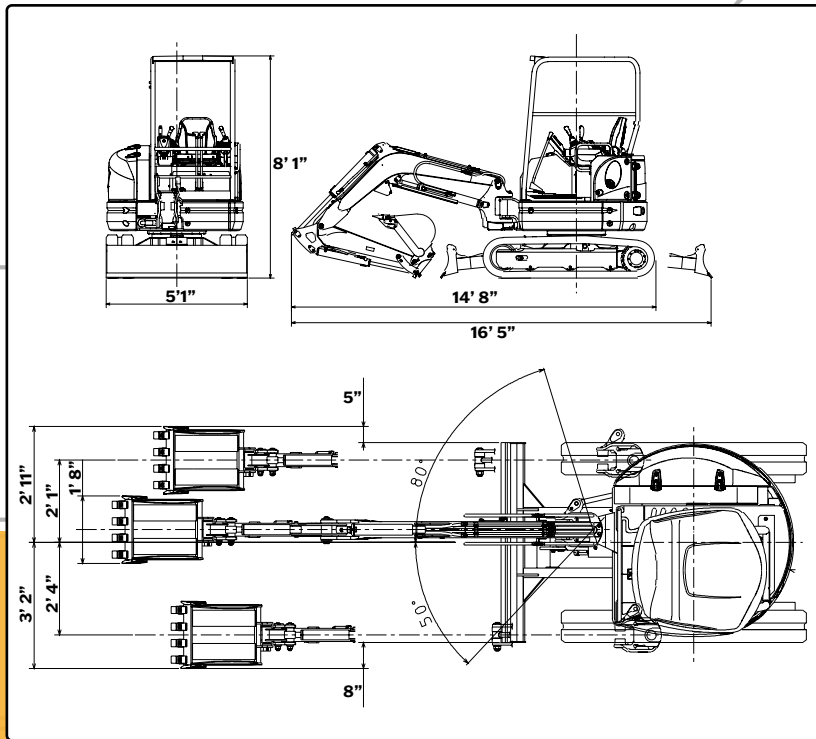

HD30V5	Working Ranges
A: Max Digging Radius	16' 11"
B: Max Digging Depth	9' 9"
C: Max Vertical Dig Depth	8' 6"
D: Max Dumping Height	11' 6"
E: Max Digging Height	15' 11"
F: Min. Front-turn Radius at Right Boom Swing	6' 10"
	6'

HD30V5

KATO
 COMPACT EXCAVATOR SALES, LLC

www.KATOCES.com

400 Production Court
 Elizabethtown, KY 42701

(800) 538-1447 | Fax: (270) 737-0419

Performance	
Bucket Capacity	3.2 ft ³
Bucket Width	18"
Operating Weight	7,084 lbs.
Transport Weight	6,658 lbs.
Swing Speed	9 rpm
Travel Speed (Low/ High)	1.7 / 2.9 mph
Gradeability	30°
Ground Pressure	4.1 psi
Bucket Digging Force	6,548 lbs.
Engine	
Model	YANMAR 3TNV88F
Output Rating	23 hp @ 2200 rpm
Fuel Tank Capacity	11 gal.
Boom Swing System	
Type	Offset Boom w/ Hydraulic Cyl.
Swing Angle (L / R)	50° / 80°
Hydraulic System	
Total Hydraulic System Flow	25 gpm
Max Auxiliary Hydraulic Flow	15 gpm
Dozer Blade	
Size	1' 3" x 5' 1"
Lift Above / Drop Below Ground	1' 3" / 1' 6"